

Type 110

Pressure Regulator Series

Features

- Highly Accurate Pressure Regulation
- Large Port Sizes Available:
3/8, 1/2, 3/4 and 1 NPT
(BSPP and BSPT also Available)
- Adjustment Stem Locking Capability
- High Forward Flow Capacity - 150+ SCFM
- High Exhaust Capacity
- Balanced Supply Valve
- Low Sensitivity to Supply Pressure Variations
- Low Sensitivity to Flow Variations

Applications

The Type 110 was developed specifically for use with Air Balancing Systems or Zero-Gravity Arms. Such systems require very small forward to reverse flow offsets for smooth operation. The precision regulators that can achieve the sensitivity requirements do not typically possess the forward or exhaust capacity to handle large balancing arms or cylinders. The Type 110 does not have this limitation. It is ideal for use in any application where precise regulation of pressure is required along with high flow or high exhaust capacity.

Other typical applications

- Valve Operators
- Air Hoists
- Web Tensioning
- Roll Loading
- Large Cylinder Loading
- Air Brakes
- Force Balance Hoists
- Gate Actuators

Description

The Type 110 combines the proven technology of the Marsh Bellofram Type 10 regulator with the large pneumatic booster of the Type 79 Relay. The result is a precise, crisply responding regulator that can achieve very large forward and exhaust flows. Forward to reverse flow offset is minimized by the capsule operated, servo-control system located in the upper portion of the regulator. This servo-control system supplies a pilot pressure to the large integral pneumatic booster. The large supply and exhaust orifices of the integral booster enable this regulator to produce very high forward and exhaust flow rates. Few regulators can offer this combination of sensitivity and large flow capacity.

As with all of the Type 10 regulators, the stainless steel measuring capsule is the "heart" of the Type 110 Pressure Regulator. Originally developed for sensitive aircraft altimeters, this precision-sensing element provides the energy to activate the servo-control mechanism. It provides greater regulation and accuracy while eliminating the problems usually encountered with range springs and conventional diaphragms. Because of the balanced supply valve in the integral pneumatic booster, the Type 110 can work with higher supply pressures (250 PSIG) than many other regulators.



Type 110
Pressure Regulator Series

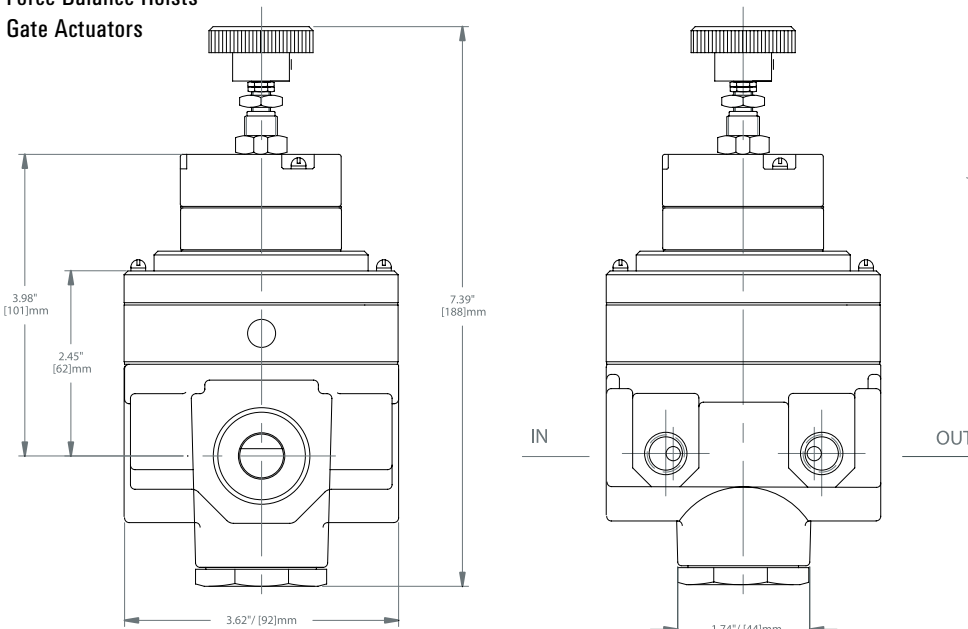

	Type 110
Maximum Supply Pressure	250 PSIG / 17.2 BAR
Output Pressure Ranges	2-25 PSIG / 0.14-1.7 BAR
	2-50 PSIG / 0.14-3.5 BAR
	2-110 PSIG / 0.14-7.6 BAR
Port Sizes	3/8, 1/2, 3/4, 1 NPT, BSPT or BSPP
Effect of Supply Pressure Variation on Outlet Pressure	0.01 psig / 0.6 mBAR change in output for a 25 psig/1.7 BAR change in supply pressure
Sensitivity	1/4" / 6.4 mm of water column
Air Consumption	14 scfh / 6.6 slpm @ max output pressure
Forward Flow Capacity (100 psig / 6.9 BAR supply, 20 psig / 1.4 BAR set point)	3/8 NPT - 110 SCFM+ / 3105 SLPM
	1/2 NPT - 110 SCFM+ / 3105 SLPM
	3/4 NPT - 200 SCFM+ / 5645 SLPM
	1 NPT - 200 SCFM+ / 5645 SLPM
Exhaust Capacity (based on raising output 5 psig / .34 BAR above 20 psig / 1.4 BAR set point)	30 scfm / 847 slpm
Temperature Range	-20° to +160° F -29° to +71° C
Weight	5.4 lbs / 2.45 Kg

Type 110 Ordering Information

	Part Number	Port Size (NPT)	Pressure Ranges	
			BAR	psig
T110	960-510-000	3/8	0.1-1.7	2-25
	960-511-000		0.1-3.5	2-50
	960-512-000		0.1-7.6	2-110
	960-513-000	1/2	0.1-1.7	2-25
	960-514-000		0.1-3.5	2-50
	960-515-000		0.1-7.6	2-110
	960-516-000	3/4	0.1-1.7	2-25
	960-517-000		0.1-3.5	2-50
	960-518-000		0.1-7.6	2-110
	960-519-000	1	0.1-1.7	2-25
	960-520-000		0.1-3.5	2-50
	960-521-000		0.1-7.6	2-110

For BSPT or BSPP pipe threads, add BSPT or BSPP to the end of the part number. For mounting bracket, order P/N 607-293-000

Type 110 Materials of Construction

Body, bonnet and housing	Die Cast Zinc Alloy
Capsule and adjustable screw	Stainless Steel
Spacer	Aluminum
Diaphragm	Nitrile Elastomer and Polyester Fabric
Trim	Stainless Steel, Brass, Plated Steel, Acetal
Knob	Phenolic Plastic

Type 110: Forward Flow Curve, 3/4 and 1 NPT

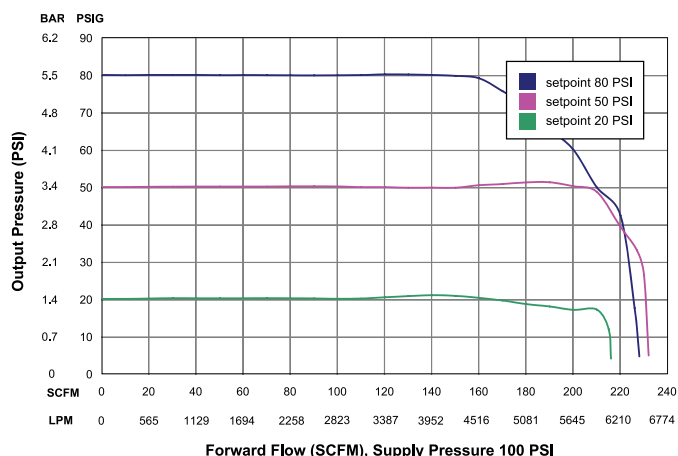

Type 110: Forward Flow Curve, 3/8 and 1/2 NPT

@ 100 PSIG Supply Pressure

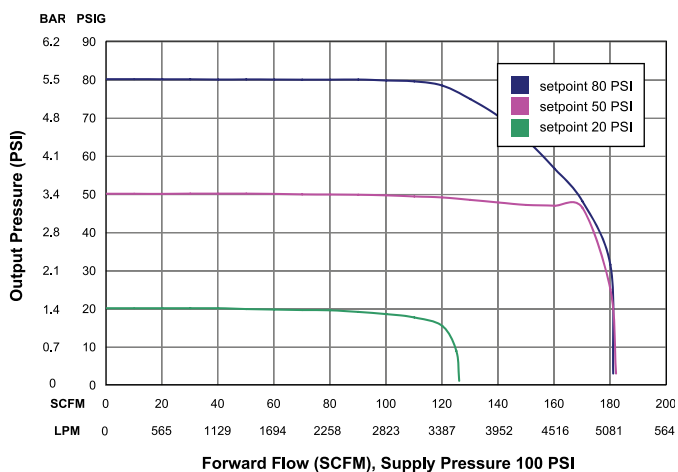

Type 110: Exhaust Curve

